

**PLEASE READ THE INSTRUCTIONS CAREFULLY BEFORE FITTING THE KIT.**

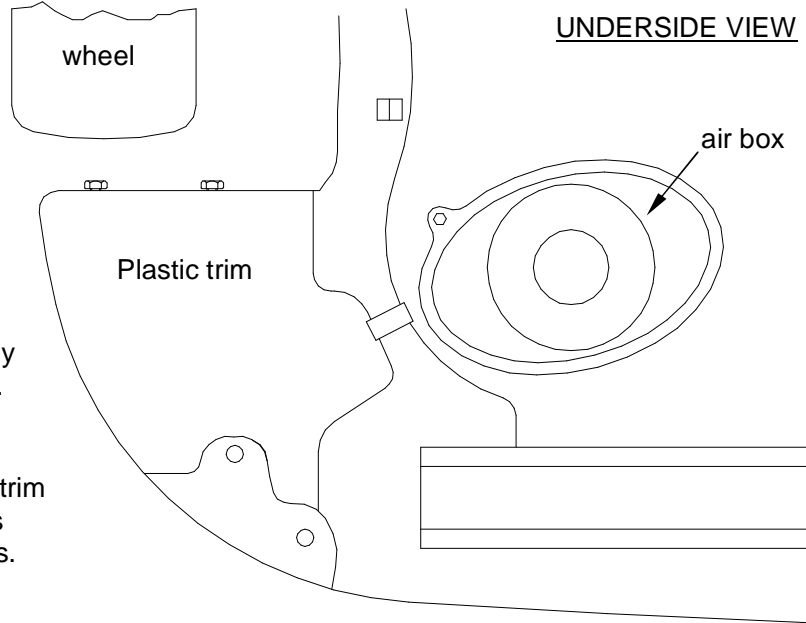

Your car and the engine bay should look like the ones in these pictures, if not then talk to your kit supplier. Should you still have a problem, call K&N customer services. Tel: 01925-636950. Fax: 01925-418948.

**Drawing A**



1. Taking all of the necessary safety precautions as per the manufacturers instructions, raise the front of the car.
2. Remove the vehicle undertray by removing the 5 screws and 2 clips.
3. If necessary remove the plastic trim on the L.H.S. lower arch liner. This will reveal the inner arch and horns.

**Drawing B**

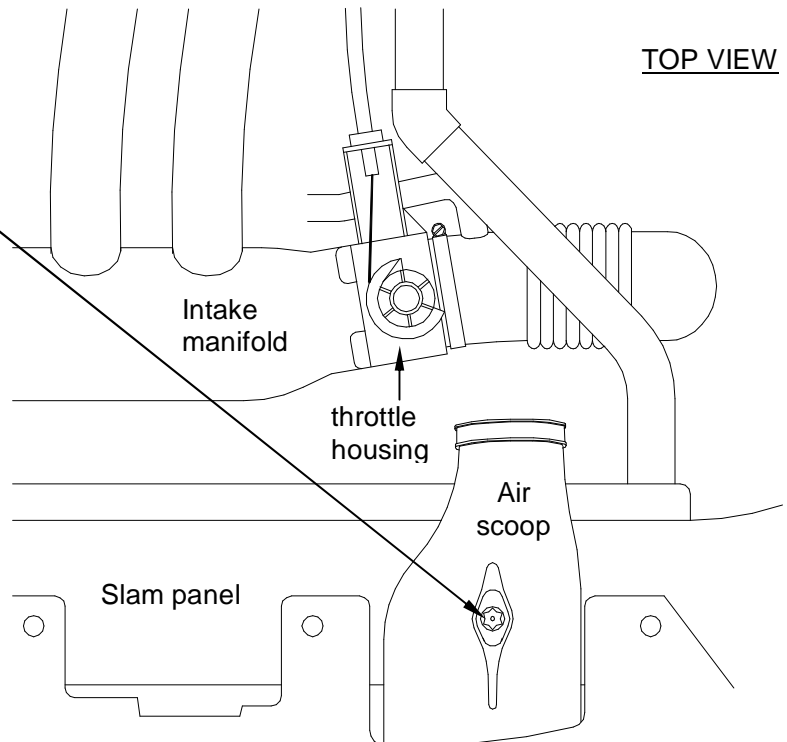

1. Unscrew and remove the intake scoop / intake hose from the slam panel and air box assembly.
2. Unclip and remove the intake hose from the air box, leaving the intake hose connected to the throttle housing.

Drawing C

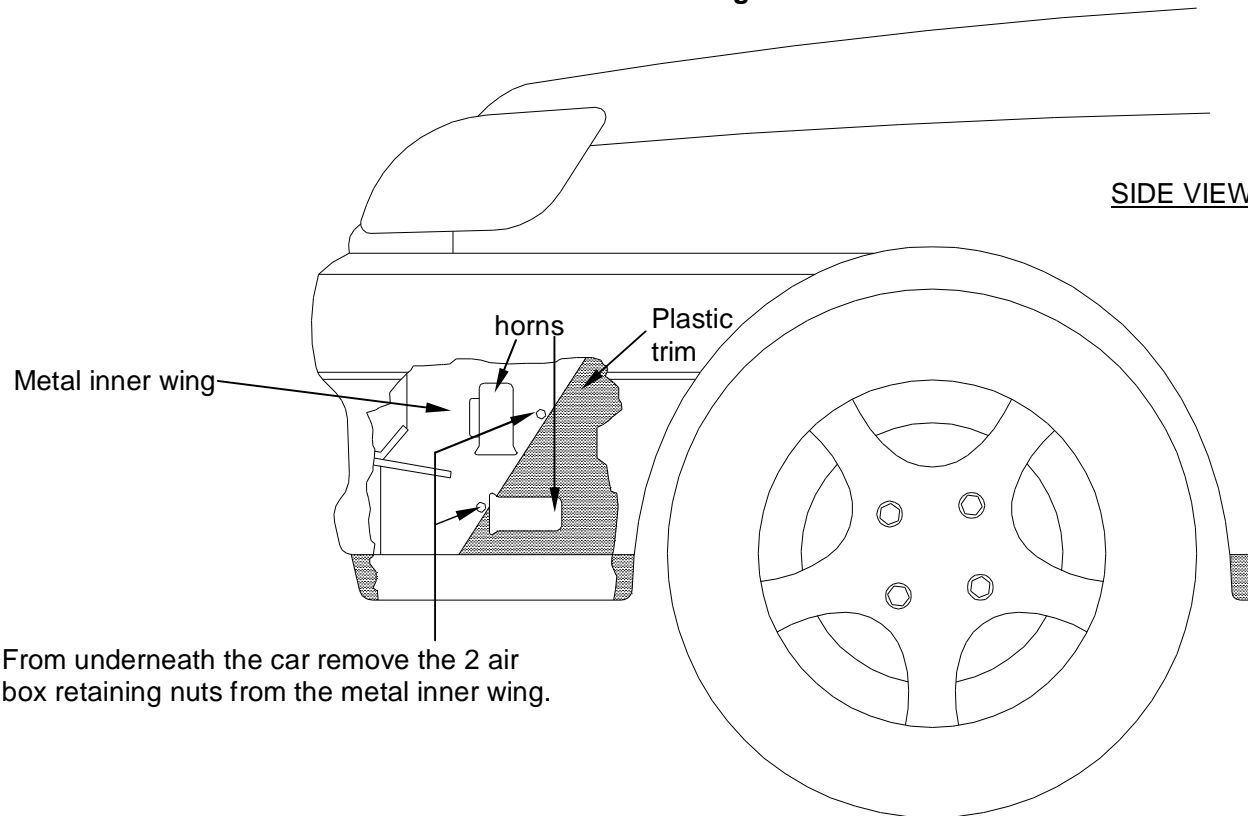

From underneath the car remove the 2 air box retaining nuts from the metal inner wing.

Drawing D

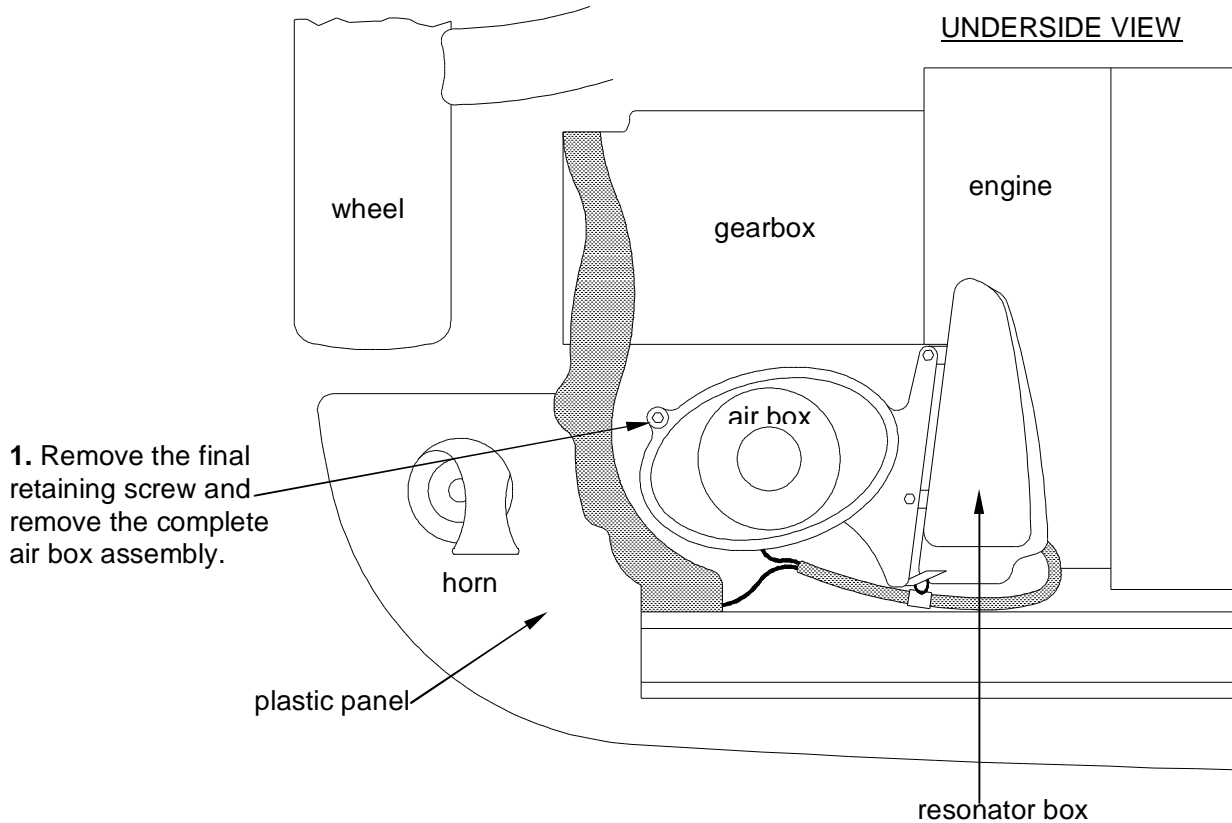

1. Remove the final retaining screw and remove the complete air box assembly.

Drawing E

UNDERSIDE VIEW

1. Fit the filter onto the metal tube up to the step in the filter base. Do not push in beyond the step as this will affect air flow. Tighten the clip until the filter just turns, then give the clip one full turn (360 degrees) **no more. Do not overtighten the clip.**

2. Fit the filter assembly into the standard intake hose and firmly tighten the clip.

3. Fit the new support bracket between the filter lid and gearbox bell housing bolt. Secure the bracket to the gearbox using the standard bell housing bolt and secure to the filter using the M6 x 16mm screw supplied.

4. Refit the plastic trim and undertray previously removed.

5. Refit the intake scoop and hose to the slam panel.

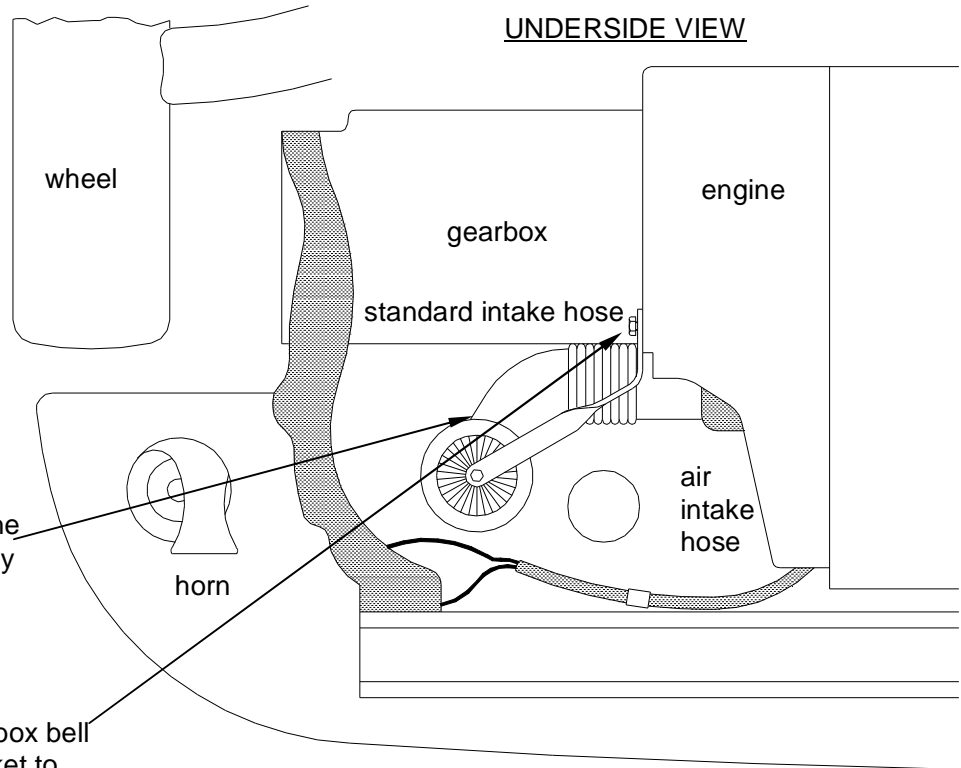

Photo F



Pierce / drill two 3mm holes in the front lower spoiler, secure the new rubber cold air scoop to the spoiler using a long plastic tie. Secure the rear of the scoop to the lower cross member or harness using a long plastic tie supplied. (The air scoop is supplied to direct cold air at the filter).

**Tuning.**

**CAT. Cars.** No adjustments are required.

An increase in fuel may be required if further engine modifications are to be carried out.

**Filter maintenance.**

Under normal conditions clean and reoil the filter at approx. 40,000 miles / 65,000 Km.

**Use only K&N cleaner and oil** and follow the instructions carefully.

**K&N filters are pre-oiled ready to fit.**

**The advantage's of K&N's cold air intake system.**

Cooler air being denser, will show positive improvements in power over filter systems that draw hot air from the engine bay.

This Kit Should Contain:

- 1 x Clamp On Filter.
- 1 x Bracket.
- 1 x Metal Tube.
- 1 x Rubber Cold Air Scoop.
- 1 x Instruction Sheet.
- 1 x Instruction Pack :-
  - 1 x Filter Maintenance Sheet.
  - 1 x Leaflet.
  - 1 x K&N Window Sticker.
  - 1 x Million Mile Warranty.
- 1 x Fixing Kit :-
  - 1 x #48 Hose Clip.
  - 1 x M6 x 16mm Screw.
  - 1 x 6mm Spring Washer.
  - 1 x Flat Washer.
  - 3 x Long Plastic Ties.

**FITTING YOUR 57i KIT**

If you are not fitting the kit **it is essential** that the person fitting the kit (eg. Mechanic) **carefully follows these particular instructions** even if they have fitted K&N kits before. This will save you both time and money. Kits fitted incorrectly may show a loss in performance, e.g. the positioning of the essential cold air hose, (flexi expandable and rubber hoses are used).

**A final check** under the bonnet, by yourself with the instructions, would seem sensible.